

FULL THROTTLE™ and © 1994 LucasArts Entertainment Company. All Rights Reserved. Used Under Authorisation. The LucasArts logo is a registered trademark of LucasArts Entertainment Company. LucasArts, INSANE, SCUMM and iMUSE are trademarks of LucasArts Entertainment Company. iMUSE U.S. Patent No. 5,315,057. All other trademarks are hereby acknowledged as the proprietary property of their respective owners.

Virgin Interactive Entertainment (Europe) Limited,  
338A Ladbroke Grove, London W10 5AH

# FULL THROTTLE™

## IBM PC CD-ROM REFERENCE GUIDE

### CONTENTS:

Your Full Throttle package should contain these important items:

- One Full Throttle CD
- One User's Manual
- This Reference Guide
- Fun stuff we threw in at the last minute

### STARTING THE GAME FOR THE VERY FIRST TIME:

Before playing Full Throttle, you must use the installation program to configure your sound card and to install a few important pieces of data on your hard drive. Note: the Install and Game files that will be saved to your hard drive will require about 1 megabyte of Hard Drive space.

**INSTALL.** After putting the Full Throttle CD in your

CD ROM drive, from the DOS prompt, switch to your CD drive root directory, type INSTALL, and press RETURN. Note: you CANNOT use the "MSDOS prompt" via Windows to boot up the game. You MUST exit Windows and return to DOS before attempting to launch the game.

The Install program gives you access to important information (like Troubleshooting). To install the FULL THROTTLE game files, click the INSTALL FULL THROTTLE button and follow the instructions provided on the screen. Files will be copied to your hard drive and you will be given the opportunity to configure your sound card. NOTE: Once you have configured your sound card for Full Throttle, you will not have to do it again (unless you make changes to your hardware), for the Install program will save the settings to your hard drive. When you are finished with the install program, select EXIT. If you successfully installed the game, you will now be in the directory you specified.

Now, simply type THROTTLE, press RETURN, and get ready to play the game!

### **PLAY IT AGAIN, BEN:**

The next time you play the game, you will not need to run the INSTALL program again. Simply put the Full Throttle CD in your CD Drive, go to the directory on

your Hard Drive in which you installed the game (specified by your choice during the INSTALL program - defaults to THROTTLE) and from there, type THROTTLE and press RETURN.

### **LAUNCHER**

The Full Throttle Install/Launcher offers opportunities for you to troubleshoot any problems you may encounter. If you do experience problems, be sure to consult the Troubleshooting Guide in the Install/Launcher before calling Product Support.

### **KEYBOARD/CURSOR CONTROLS**

Full Throttle may be played with a mouse, joystick, or keyboard. The controls default to keyboard and mouse. If you would like to change controls to joystick, simply hold down the CTRL key and type J.

**VOLUME CONTROL:** The Save/Load Control Panel (F1 key) also has volume sliders for music, voice, and sound effects. Moving the slider to the right makes the volume louder, to the left, softer. These sliders have been preset to levels which give optimum sound quality, assuming your sound card volume is set to an adequate level. If you want to change the overall volume of sound, it is best to do so using your sound card's

Walk to Pick up/  
Punch

Examine Talk to/  
Use mouth

Kick Inventory

Standard Save Game/  
Load Game Control Panel

Escape Cut Scenes

Pause Game

Music Down Music Up

Voice Down Voice Up

SFX Down SFX Up

NOTE: before using the volume keyboard keys, please read the section on volume control on page 3.

Show Inventory

Walk to/Activate /Use Verbs

Change to Joystick Controls

Toggle Text Display Options

OR Quit

Left Mouse Button

Right Mouse button

To move up, down, left, or right, first move your cursor to where you want to go, then hit the ENTER key. (Be sure to turn off the Num Lock key.)

DEMOLITION DERBY Use your mouse or arrow keys to steer AND accelerate your car.

Accelerate Accelerate

Reverse Reverse

Forward/Reverse Forward/Reverse

Left/Right Left/Right

\* \* \* \* \*

MINE ROAD When Ben is on his bike in an interactive highway sequence, you can swerve left or right by moving the mouse in those directions. If you want to select a weapon, click the right mouse button. If you want to use a weapon, click the left mouse button. If at first you don't succeed, punch, punch, punch. You can always try a bigger weapon.

Select weapon Use weapon

Keyboard controls for the highway sequence are:

Move Left Use Weapon

Move Right Scroll through weapons

volume control, if it has one. Use your sound card's configuration utility to do this or consult your sound card manual for further instructions.

You can also check the DISPLAY TEXT box to have the written text for the dialogue appear onscreen. The TEXT SPEED slider causes text to appear faster when moved to the right, slower when moved to the left.

ESCAPING. To bypass a cut-scene, press the ESC key, or press both mouse/joystick buttons at once.

RESTARTING. To restart, exit the game (via the Save/Load screen or by pressing Alt X and then Y), then type THROTTLE at the DOS prompt.

PAUSING. To pause the game, press the space bar. Press it again to resume play.

DIALOGUE. As indicated above, you can display text and adjust its display speed through the Save/Load Control Panel (F1). By using the CTRL-T key combination, you can choose whether you want Text and Voice, Text Only, or Voice Only mode. If you are reading the text and have finished a sentence, you can use the period key (.) to move to the next sentence.

MUSIC. You have the option to turn the music off. Consult the Troubleshooting Guide in the Install/Launcher for more information.

QUITTING. To quit the game, press the key combina-

tion indicated on your reference card. If you plan to return to the game you're presently playing, remember to save the game before quitting.

## MEMORY ALERT

Full Throttle requires 8 megabytes of total memory to run. If your computer does not have sufficient memory to run Full Throttle, the game will alert you when you first boot up the game. Many programs, such as Windows and memory managers, will use up much of your

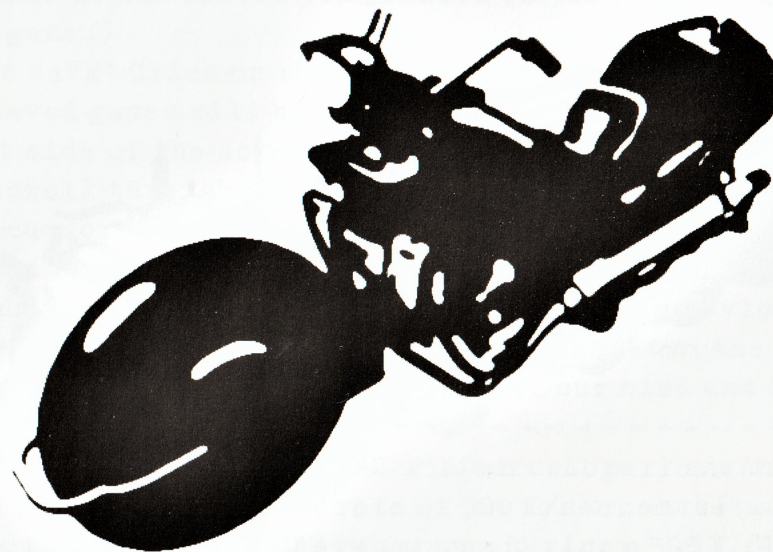

computer's RAM. To shut these programs down temporarily, follow the instructions in the Launcher program for making a BOOT DISK. A Boot Disk will allow you to start up your computer with optimum configuration for Full Throttle. Then, when you've finished playing the game, you simply eject the Boot Disk and restart your computer. Your computer's memory configuration will then return to its normal state. Please consult the Troubleshooting section of this Reference Guide or the Install/Launcher for more information.

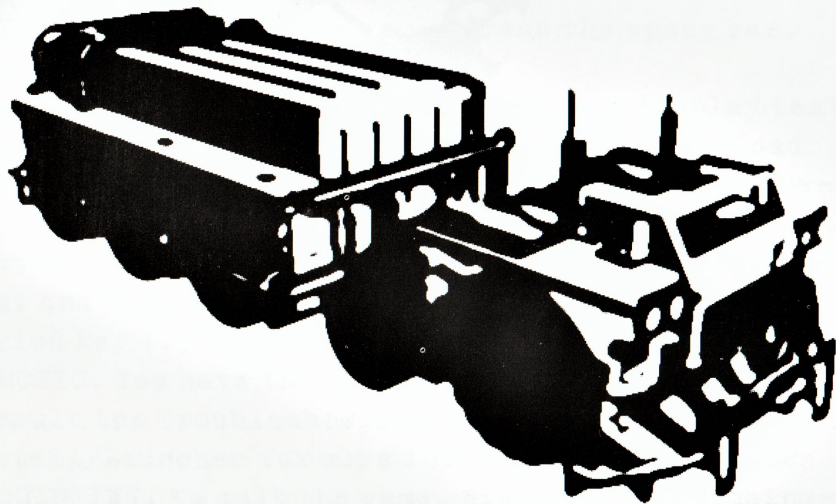

## **HARDWARE DIFFICULTIES**

Full Throttle requires an MPC Level 2\* system to run smoothly. If your system is Level 2 compatible, and you are experiencing problems, we recommend that you check with your hardware manufacturer for more information.

## **SAVE/LOAD INSTRUCTIONS**

Press F1 when you want to save or load a game. Once the save/load screen is displayed, you may move the cursor and click on SAVE, LOAD, PLAY (to return to the game as it was before you pressed F1) or QUIT (to quit the game.)

To SAVE: Click on the SAVE option. The current list of saved games will be displayed in slots along the left side of the screen. Click on the UP and DOWN arrows to scroll through the list. Select a slot by pointing the cursor to it and clicking. Now you will be able to type a new name for that slot or use the backspace key to change the existing name and save over a previously saved game. Press ENTER or click on OK to save the game. Click on CANCEL if you have changed your mind and do not

-----  
\* MPC Level 2 means that a CD Player will perform on a 486 at a sustained transfer rate of 300 K/sec. while using less than 60% of the CPU resources during a 300 K read.

wish to save it. Remember: Each saved game will take approximately 80k of your hard disk space. NOTE: Please read the Troubleshooting Guide in the Install/Launcher for information on saving games in the interactive Mine Road sequences.

To LOAD: Click on the LOAD option. The current list of saved games will be displayed in slots along the left side of the screen. Click on the UP and DOWN arrows to scroll through the list. Select a slot by pointing the cursor to it and clicking. When clicking on a saved game, it loads automatically.

WARNING: Loading a previously saved game will cause you to lose the game you are currently playing. If you think you will want to return to the game as it was before you pressed F1, be sure to SAVE the game before loading a different one.

## **TROUBLESHOOTING AND README**

For updates on the information found in this Reference Guide, please consult the menu item entitled Troubleshooting in the Install and Launcher programs. If you're still having difficulty, be sure to read the README file located in the root directory of the CD and in the Launcher.

This section provides you with some solutions to

gamers' most common technical problems. If you are having difficulty getting Full Throttle up and running, please refer to this section and the game's Troubleshooting Guide in the Install/Launcher program before contacting technical support.

Full Throttle requires 8 megabytes of RAM in order to run. While your machine may have 8 megabytes installed, many programs, such as RAM drives or hard disk caches, will use part of that memory. It is also possible that the other programs that are pre-loaded into your computer's memory will conflict with our software. Never fear. You DO NOT have to erase all of your software just to get our game to run. Simply make one of our handy-dandy boot disks and try running the game again.

HOW TO MAKE A BOOT DISK: In order to use the Boot Disk program provided by Full Throttle, you will need a clean high density floppy disk that may be erased and re-formatted. To make the boot disk, select MAKE BOOT DISK from the Launcher program or use the program entitled BOOTFULL in the resource directory of your Full Throttle CD ROM. BOOTFULL.EXE is also copied to the game installation directory. Then, simply follow the instructions and voilá! Your new boot disk will be ready for use!

Note: A boot disk does NOT affect your hard drive in any permanent way. To get your hard drive back to its normal state, simply restart your computer without inserting the boot disk.

**SOUND CARDS:** If you are experiencing problems with your sound card, try running the diagnostic software that came with your card. Most sound card problems are due to configuration errors. If you are using a sound card that is not listed on the system sticker on the outside of the Full Throttle box, or are running a sound card in emulation mode, your sound may not perform optimally. Sound performance will also be affected if you do not have enough free RAM. If your computer does not have enough free RAM, the program will warn you during start-up.

**MOUSE SETUP:** If you are having difficulty with your mouse, please be certain that its device driver has been installed and loaded properly. Windows and other software packages often have built-in mouse drivers that will not function outside of their own environment. Most mouse drivers can be loaded by typing "mouse" or a similar command at the C: prompt. Please consult the original documentation that came with your mouse to find more information about enabling commands.

Erratic behaviour in a mouse may also be due to a hardware conflict or incompatible mouse driver. Please check with your mouse's manufacturer to be certain you are using the most recent mouse driver version.

## **DEMOS:**

Hot-off-the-press demonstrations of our up-and-coming games are included on your Full Throttle CD. To see them, first install them on your hard drive by selecting RUN/INSTALL DEMOS from the main menu. Then, select the demo you'd like to see. Note: the demos will require 10 Mb of free hard drive space.

Note: Each demo may have its own install program. Be sure to follow the instructions specific to the demo you'd like to play when trying to run it.



**ANY QUESTIONS?**

Call our Customer Services line on:

**0181-964-8242/9361**

When you call please be sitting in front of your computer with paper and pen, and gather as much pertinent information about your computer as you can assemble: make, model, peripherals, RAM and disk size, graphics card, monitor and the information in your CONFIG.SYS and AUTOEXEC.BAT files.

You can also write to Customer Services at:

Virgin Interactive Entertainment (Europe) Limited,  
338A Ladbroke Grove, London W10 5AH

Customer Services hours are 10:00 am to 1:00 pm and  
2:00 pm to 5:00 pm, Monday to Friday.

-----  
**WHERE TO FIND US ONLINE**

**CompuServe**  
Game Publishers Forum A  
(GO GAMAPUB)  
section 7  
Or send e-mail to ID#  
75300,454

**America Online**  
Keyword "LucasArts"  
Or send e-mail to  
LUCASARTS3  
**Internet E-Mail**  
75300.454@compuserve.com  
Or send e-mail to  
LucasArts3@AOL.com

Technical Support FAX

**0181-960-9900**

Technical Support BBS

**0181-964-4033**

**NEED MORE HINTS?**

Please do not call Customer Services for HINTS, as they do not give hints over the phone. However, you may call our 24-hour automated hint line at:

**0891-333529**

This service costs 39p per minute cheap rate, and 49p per minute at other times. You must obtain permission from the person who pays the bill to use this service. Max 7 minutes. Price as advertised correct at time of release (May 1995).

Service available to UK residents only.